

## SOS SILENT INSTALLATION AND TESTING INSTRUCTIONS

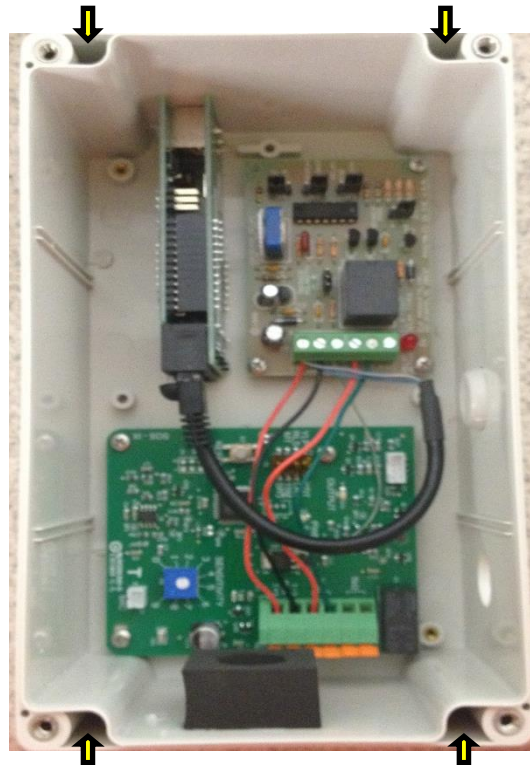

Channels for mounting screws—one in each corner.

### Mounting the Unit

1. Remove the face plate of the SOS SILENT unit.
2. Identify a location inside the fence to mount the SOS SILENT unit. Do not select a location inside the gate operator enclosure or near any noisy machinery that could interfere with the sensor picking up the siren.
3. Using the screws provided, mount the SOS SILENT unit with the microphone facing down. The enclosure has four pre-drilled holes for mounting. **WATER DAMAGE** will void the warranty. If additional holes are drilled into the enclosure please make them water tight.

**Note:** If mounting the SOS onto metal, do not allow drilled metal pieces to collect onto the magnetic field that is present around the back side of the microphone.

### Connecting the Power and Gate Operator (image 3)

---

4. Run 22 AWG stranded wire (not included) from a power source such as the gate operator unit or a battery to the power terminals on the SOS IX board. **The power must be 12 volts DC.** There is currently a wire in this terminal that will power the RFID board. You will leave this wire in place and add the power wire from the gate operator.
5. Press down firmly on the orange levers above the power receptacles and insert the wire. Once power is connected the Power/Sound – amber light LED will blink every 10 seconds.
6. Run two 22 AWG stranded wires from the gate operator unit – one from the COM (“common”) terminal and one from the NO (“open”) terminal.
7. Before connecting the wires to the SOS unit, test the gate by touching the two wires together. The gate should open.
8. If the gate opens, press down firmly on the orange levers above the SW1 receptacles and insert the wires. Again there are wires in these terminals and you will just add the additional wires in these terminals.
9. Wires can be brought into the enclosure through the small plugged hole at the bottom, the ½ inch conduit tap on the side above the reset button or drill your own hole through the back. **WATER DAMAGE** will void the warranty. If additional holes are drilled into the enclosure please make them water tight.

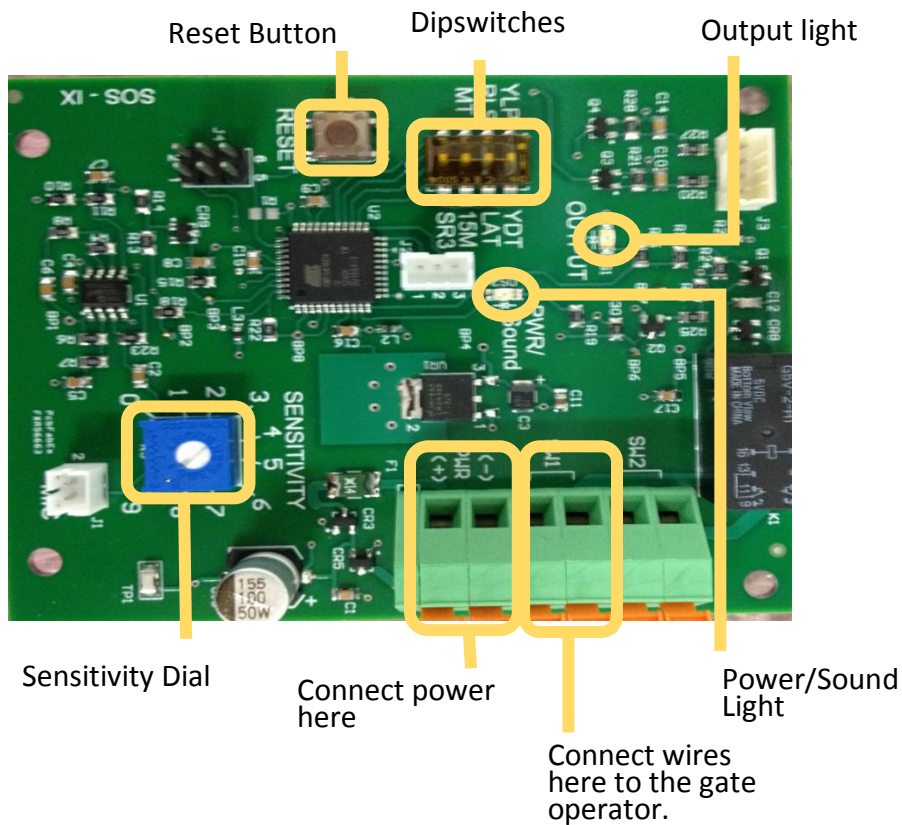

**IMAGE 3**

---



**IMAGE 4**



**IMAGE 5**

### **Connecting the Antenna (images 4 and 5)**

---

10. Cut the coaxial cable to desired length. The shorter the cable the less interference.
11. Unscrew the cover off the antenna. Image 4
12. Strip the coaxial cable. Screw down the copper center wire onto the copper antenna base (red).
13. Twist the remaining mesh sheath insert into the crimp connection (blue). Crimp the connection tight.
14. Screw the cover of the antenna back on.
15. Attach the coaxial cable to the top of the SOS SILENT.



**IMAGE 6**

### **Mounting the tag to the vehicle (image 6)**

---

16. Mount the Active RFID tag to the vehicle behind the grill, behind the bumper or in the light bar using the industrial strength sticky tape provided. The tag should not have metal pieces between it and the reader at the gate. Behind the radiator will not work.

## Testing the Unit

---

Properly testing the unit involves two sensitivity tests: a CD test and a live siren test. SOS recommends keeping the sensitivity at the lowest setting that will still trigger the gate.

RFID tags need to be more the 300 feet away since they will trigger the unit when within range. First test the SOS Function without an RFID tag present. Then test the RFID tags.

17. Begin the CD test by turning the sensitivity dial clockwise to setting 9 (maximum sensitivity).
18. Using the Yelp Siren CD provided, test the sensor with a portable CD player at the loudest setting. Hold the portable CD player close to the microphone located on the bottom of the unit. The gate should open within 3 seconds. In the absence of the CD, go to our website at [www.sosgate.com](http://www.sosgate.com) to download a yelp sound and burn it to a CD or download it to your phone.
19. Bring an RFID tag into range and the gate will open.
20. Next, begin the live siren test by turning the sensitivity dial down to 7.
21. Have an emergency responder run their yelp siren for up to 10 seconds or until the gate is triggered. If the gate does not open, increase the sensitivity and test again. **Note:** Every time the siren is interrupted or changed the digital processor begins the process over again, so it is best to leave the siren on until the gate triggers.
22. Lastly, have the emergency responder drive past the gate on the road with their yelp siren on. This is to ensure the sensitivity is not too high so as to prompt the gate to false trigger at the sound of a passing emergency responder. Adjust the sensitivity dial as needed.

SOS recommends inviting an emergency responder out once each year to help you conduct a live siren test. This will ensure the unit remains in good working order. Most emergency responders will gladly perform this service but it is the gate owner's responsibility to invite them.

## Adjusting Dipswitch Settings

---

**Dipswitch 1:** When this switch is in the YLP position, the sensor will detect only a "yelp" siren and will open the gate after a valid signal has been detected for 3 seconds. When the switch is in the YDT position, the sensor will open the gate once it has detected any siren or any continuous loud noise (such as a loud engine) for 4.5 seconds. To avoid false triggers, SOS suggests keeping this switch in the YLP position.

**Dipswitch 2:** When this switch is in the RLS position, the sensor will not interfere with the gate's normal closure time. When the switch is in the LAT position, the gate will remain open until the reset button is pushed or power is recycled. This will override any other programming for closing times and the gate will remain open until it is reset. There is a reset button on the outside of the enclosure.

**Dipswitch 3:** When this switch is in the MT position, the sensor will not interfere with the gate's normal closure time. When the switch is set to 15M, the gate will remain open for 15 minutes. **Note:** When switch #2 is in the LAT position, the settings for switch #3 are irrelevant.

**Dipswitch 4:** This dipswitch is not currently being used.

---